

120 Minute Transparent Wall Solution

SuperLite II-XL 120 is a fire resistive, technically advanced glazing product that blocks radiant heat transfer to meet ASTM E119 requirements. SAFTI *FIRST* was the first to provide this new technology to the USA in 1982. SuperLite II-XL products have been tested to the stringent wall standard and therefore are considered a “transparent wall.” Fire resistive glazing allows for greater design flexibility while other fire protective glazing products, such as ceramics, are limited by code to interior applications of 45 minutes or less and to 25% of the wall area.

SuperLite II-XL, when used with an equally rated heat barrier framing system such as SAFTI*fire*™ GPX™, provides floor-to-ceiling and wall-to-wall design flexibility with unsurpassed clarity and the added benefit of sound reduction. These products provide the maximum life safety and property protection with unlimited design freedom. SuperLite II-XL products may be customized to meet bullet, blast and hurricane resistance, as well as enhanced energy performance.

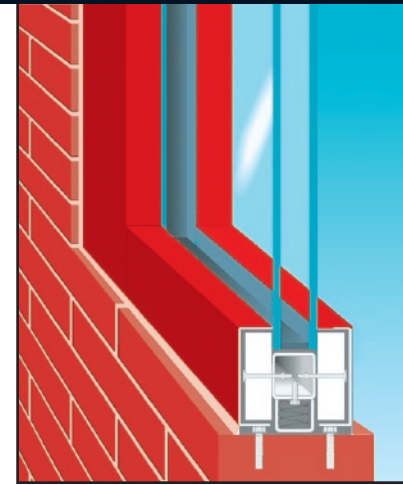

SuperLite II-XL 120 minute in SAFTI*fire* GPX Framing



FIRE RATED



HOSE STREAM



RADIANT HEAT



IMPACT RATED



THERMAL SHOCK



POSITIVE PRESSURE

SuperLite II-XL Product Features

- **Meets all fire code and testing requirements and therefore is not subject to any limitations other than the use of proper framing and lite sizes.**
- **Acoustical barrier with high STC ratings.**
- **Glass unit tempered to meet the highest federal impact safety standard CPSC 16CFR 1201 Cat. II, which requires withstanding 400 ft. lbs. of impact.**
- **Available in virtually any custom architectural make-up: laminated, insulated, tinted, patterned, frosted, mirrored, reflective, curved, segmented, decorative, and more.**
- **SuperLite II-XL technology is the basis for specialty features such as bullet, blast, attack, or hurricane resistance, and enhanced acoustical and energy performance.**
- **Positive Pressure fire rated.**
- **1-1/4" to 1-1/2" thin profile.**
- **USA manufactured for fast delivery.**

Fire Rating*	Application	Max. Lite Area**	Max. "W"	Max. "H"	Stops***	Testing
90 minutes	Doors	4,876 sq. in	60"	124"	1"	
120 minutes	Sidelites	4,876 sq. in	124"	124"	1"	
120 minutes	Windows / Transoms	4,876 sq. in	124"	124"	1"	
120 minutes	Walls	4,876 sq. in	124"	124"	1"	

* 90 minute doors are allowed in most 120 minute applications.

** SuperLite II-XL is tested to ASTM E119 wall standards and has no overall area limitations for its use in walls, windows, transoms, and sidelites.

*** SuperLite II-XL is tested and approved with 5/8" stop heights. However, 1" stop heights are recommended for optical irregularities that might occur along the perimeter of the lite.

Product Specifications

Thickness: 1-1/4" to 1-1/2" (32 - 39mm)
 Weight: 12 lbs./sq. ft.
 Appearance: Clear, wireless
 U-Value: .30
 Light Transmission: 81%
 STC Rating: 44 (standard)



Listed and Labeled

SuperLite II-XL is listed and labeled with positive pressure by Intertek/Warnock Hersey, Inc. Intertek/Warnock Hersey permanent labels are applied to all lites.



Standards

UBC STD 7-1-1997, NFPA 251-2006, UL 263-2003, ASTM E-119-2008, ULC CAN-S101-2007 for fire resistive wall assemblies. UBC STD 7-2-1997, NFPA 252-2008, UL10B-2008, UL10C-1998, ASTM E-2074-2000, CAN4-S104-1985, ASTM E-152-1981 for door assemblies. UBC STD 7-4-1997, NFPA 257-2007, UL9-2000, ASTM E-2010-2001, CAN4-S106-1985, ASTM E-163-1984 for window assemblies.

Delivery

Allow 15 days from confirmed order. Quick ship is available upon request.

Typical Framing for SuperLite™ II-XL 120-minute

Visit www.safti.com for downloadable 3-part specifications, full CAD details, and a complete selection of SAFTI^{fire}™ Framing.

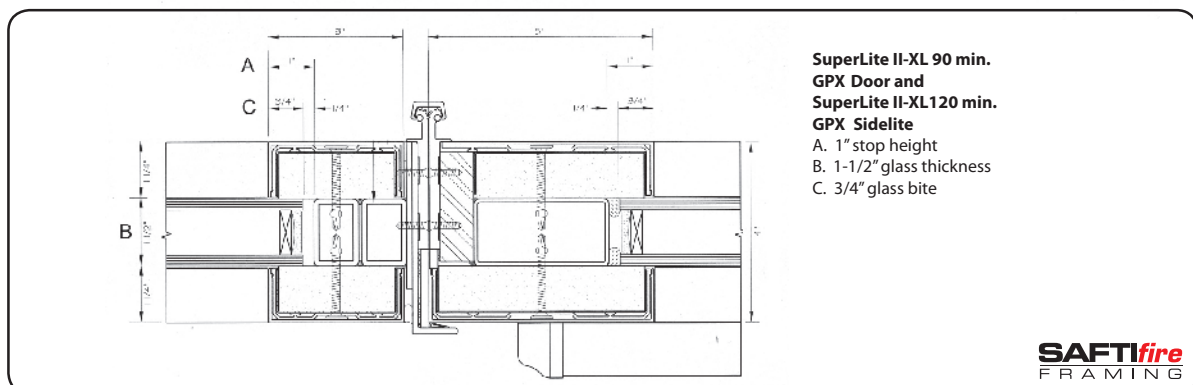
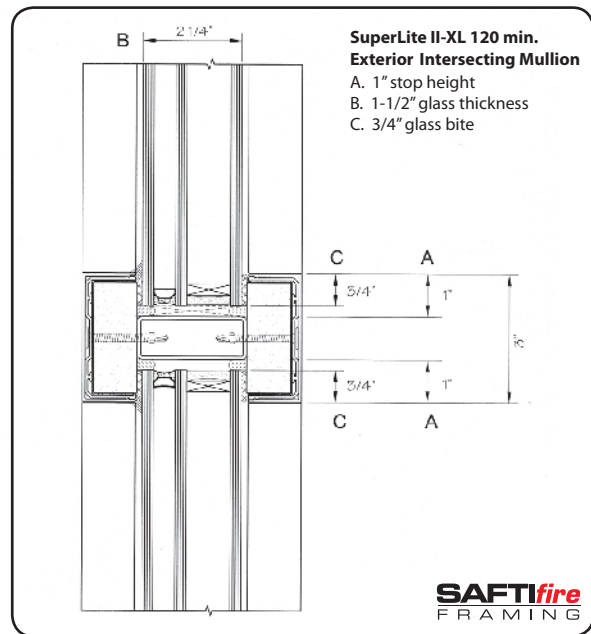
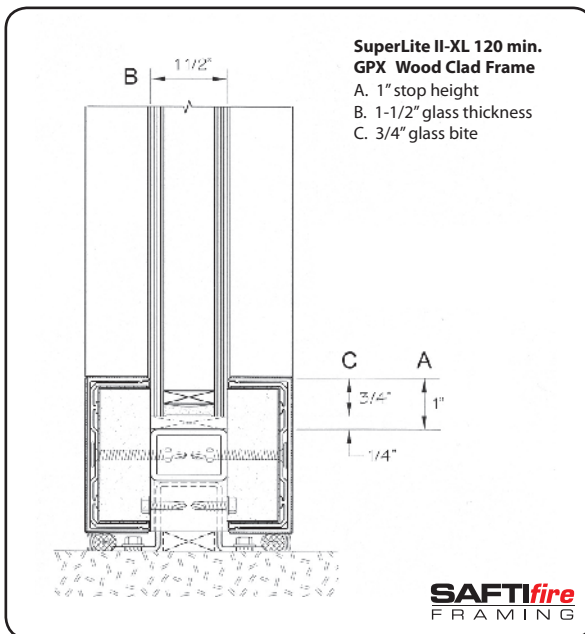

The information provided herein is for general reference only. SAFTI^{FIRST} has endeavored to provide current information and cannot warrant or be responsible for errors and omissions.